



*Operation Manual*

***2.5T HD Low  
Profile  
Trolley Jack***

*STJ2.5HDLP*

# 1 General Description

## Product Description

Hydraulic trolley jack is designed to lift, but not support, one end of a vehicle. Immediately after lifting, loads must be supported by a pair of appropriately rated jack stands.

## Specifications

Capacity	2.5 TONNE
Minimum Height	75 mm
Maximum Height	500 mm
Length	685 mm
Weight	32.5 KGS

## 2 Safety Information

**Important:** Read these instructions carefully. NOTE THE SAFE OPERATIONAL REQUIREMENTS, WARNINGS AND CAUTIONS. USE THIS JACK CORRECTLY AND WITH CARE FOR THE PURPOSE FOR WHICH IT IS INTENDED. Failure to do so may cause damage or personal injury and will invalidate the warranty. Retain THESE INSTRUCTIONS for future use

To avoid personal injury or property damage during operation, read and follow all CAUTIONS, WARNINGS, and INSTRUCTIONS, included with or attached to each product.

WE CANNOT BE RESPONSIBLE FOR DAMAGE OR INJURY RESULTING FROM UNSAFE USE OF PRODUCT, LACK OF MAINTENANCE, OR INCORRECT PRODUCT AND SYSTEM APPLICATION.

Contact us when in doubt as to safety precautions or applications.

## WARNING

- 2.1 Locate the jack in a suitable working area.
- 2.2 Inspect the jack before each use. Do not use jack if damaged, altered, modified, in poor condition, leaking hydraulic fluid, or unstable due to loose or missing hardware or parts. Make corrections before using
- 2.3 Use jack on level and solid ground, preferably concrete. Avoid tar macadam as jack may sink in. Chock wheels of vehicle.
- 2.4 Ensure the vehicle handbrake is engaged, engine is switched off and transmissions in gear (or "PARK" if automatic).
- 2.5 Ensure minimum distance of 0.5m between vehicle and static objects such as doors, walls, etc, to allow for vehicle tilting.



- 2.6 Ensure all non-essential persons keep a safe distance whilst the jack is in use.
- 2.7 Ensure there no passengers in the vehicle.
- 2.8 Place jack under only those lifting points recommended by vehicle manufacturer (see vehicle handbook)
- 2.9 Check that the lifting point is stable and centered on the jack saddle.
- 2.10 Ensure the jack wheels are free to move and that there are no obstructions.

**Danger : Use the jack for lifting only**

- 2.11 Ensure there are no persons or obstructions beneath the vehicle before lowering.
- 2.12 Use suitable axle stands under the vehicle before proceeding with any task.
- 2.13 Use a qualified person to lubricate and maintain the jack.
- 2.14 Wear ANSI-approved safety goggles and heavy-duty working gloves during use.
- 2.15 Ensure that only hydraulic jack oil is used in the jack.

**DO NOT** operate the jack if damaged.

**DO NOT** allow untrained persons to operate the jack.

**DO NOT** exceed the rated capacity of the jack.

**DO NOT** allow the vehicle to move during lifting or lowering, or use the jack to move the vehicle.

**DO NOT** jack vehicle if there is a risk of spillage of fuel, battery acid, or other dangerous substances.

**DO NOT** work under the vehicle until appropriately rated axle stands have been correctly which it is intended

**DO NOT** fill hydraulic system with brake fluid, alcohol or transmission oil. Use hydraulic jack oil only.

**DO NOT** adjust the safety overload valve

**DO NOT** use for aircraft purposes

2.16 When not in use store jack, fully lowered, in a safe, dry, childproof location.

2.17 The warnings, precautions, and instructions discussed in this manual cannot cover all possible conditions and situations that may occur. The operator must understand that common sense and caution are factors, which cannot be built into this product, but must be supplied by the operator.

## **3 Assembly**

### **3.1 Important Receiving Instructions**

Visually inspect all components for shipping damage. If any shipping damage is found, notify carrier at once. Shipping damage is NOT covered by warranty. The carrier is responsible for all repair or replacement cost resulting from damage in shipment.

#### **3.1.1 Check the parts in the carton.**

Visually inspect all components for any missing parts or damage. Refer to

**Fig. 1**



### Packing list

No.	Description	Qty
1	Handle tube 1	1
2	Handle tube 2	1
3	Jack body	1
4	Instruction Manual	1

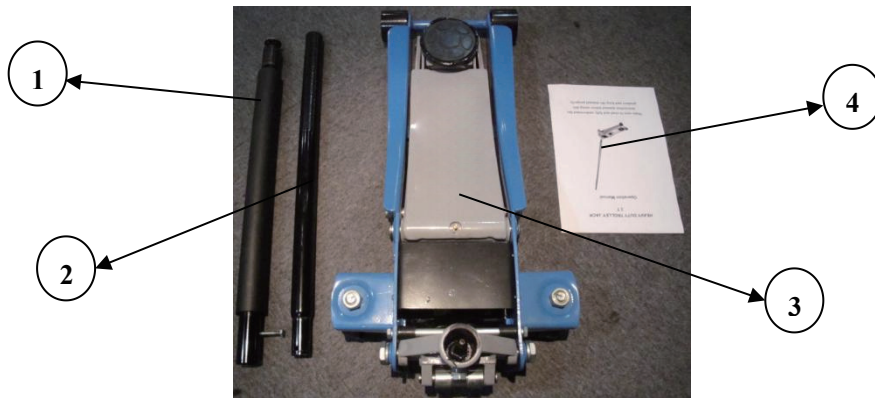

Fig 1

### 3.2 Assembly

3.2.1 The jack comprises the following parts, Jack body, Two-part pumping handle

3.2.2 Unscrew the bolt from handle tube 1, Insert the upper handle into the lower handle. Secure the two pieces together with the lock Pin (A).



(1) Handle tube 1



(2) Unscrew the bolt from handle

3.2.3 The handle socket is pressed down and supported by nylon supporting block in the package during transportation. Before assembling, please take out the nylon supporting block.

3.2.4 Undo the screw(B) in the handle socket, until it no longer protrudes into the handle socket

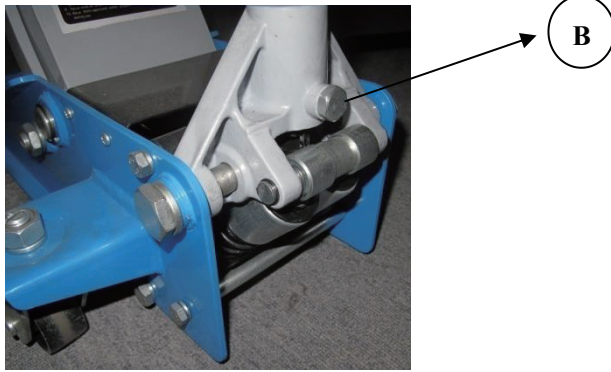

3.2.5 Insert the pump handle into the handle socket hole completely.

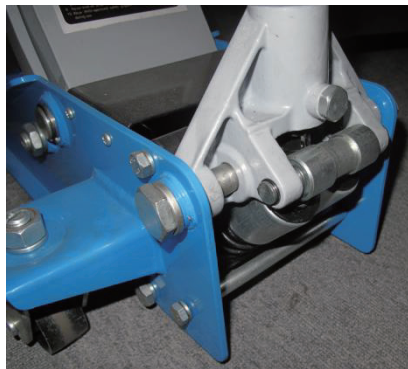

3.2.6 Ensure that the handle is correctly inserted into the socket, then tighten the handle socket screw (B). Please make sure that the handle can be turned smoothly.

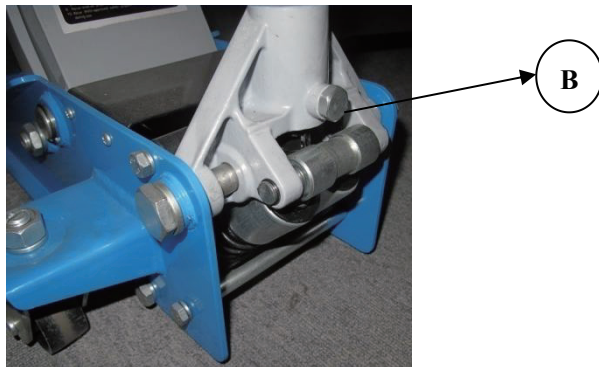

## 4. Hydraulic System Purging

- 4.1 Open the release valve by turning it two full turns counter-clockwise.
- 4.2 Pump the handle four full strokes minimum quickly.
- 4.3 Close the release valve by turning it clockwise.
- 4.4 Pumping the handle with full strokes to check if it can reach the maximum height by ten pumps.

If it can't reach the maximum height by ten pumps, please refer to the following special purging process:

- 4.5 Open the release valve by turning counter-clockwise and lower the lifting arm to



the minimum height.

- 4.6 Put the jack on a flat working table, lift the front part of the jack to make sure the front part is at least 500mm higher than the end part of the jack. See the following picture.
- 4.7 Pump the handle four full strokes minimum quickly.
- 4.8 Put the jack on a flat surface and close the release valve by turning it clockwise.
- 4.9 Pumping the handle with full strokes to check if it can reach the maximum height by ten pumps, if not please repeat the special purging process again.



## 5. Operating Instructions

**Warning!** Before use ensure you have read, understood section 1 safety instruction.

**IMPORTANT:** Before use, the operator is to visually inspect the jack for cracked welds, damaged or missing parts or hydraulic leak.

### 5.1 Raising a Vehicle

- 5.1.1 Ensure that the jack and the vehicle are on a hard, level surface.
- 5.1.2 Always ensure that the vehicle handbrake is engaged and that the vehicle wheels are chocked.
- 5.1.3 Consult the vehicle manual to determine the location of jacking points. Position the jack under a suitable lifting point.
- 5.1.4 Turn the handle clockwise, to close release valve. **DO NOT** over-tighten.
- 5.1.5 Raise the vehicle to the desired height by pumping the handle up and down.
- 5.1.6 Place axle stands beneath the locations recommended by the vehicle manufacturer.
- 5.1.7 Turn the release valve slowly counter-clockwise to lower the vehicle on to the axle stands.

### 5.2 Lowering a Vehicle

- 5.2.1 Turn the release valve clockwise to close it.
- 5.2.2 Pump the handle to raise the vehicle off the axle stands.
- 5.2.3 Remove the axle stands from beneath the vehicle.
- 5.2.4 Turn the release valve slowly counter-clockwise to lower the vehicle to the ground.

**NOTE:** When the jack not in use, **ALWAYS** leave the saddle and ram fully retracted.

**CAUTION:** Keep hands and feet away from the hinge mechanism of the jack  
**IMPORTANT:** Only fully qualified personnel should attempt maintenance or repair.

## 6. Maintenance

### 6.1 Monthly Maintenance

Lubrication is critical to jacks, since they support heavy loads. Any restriction due to dirt or rust can cause either slow jack movement, or extremely rapid jerks, causing damage to the internal components. To keep the jack well lubricated, carry out the following steps.

6.1.1 Lubricate the linkages, the saddle and pump mechanism with light oil.



Linkage (1)



Linkage (2)



Linkage (3)

6.1.2 Grease the wheel bearing and axles.



Roller Pin (right)



Roller pin (left)



Lifting arm

6.1.3 Keep all jack surfaces and warning labels clean.

### 6.2 Three Monthly Maintenance

6.2.1 At three monthly intervals, check the pump for any signs of rust or corrosion. Clean the pump as required and wipe with an oil cloth.

## 7. Trouble Shooting

PROBLEM	CAUSE	REMEDY
Jack will not lift to full height	<ol style="list-style-type: none"> <li>1. Oil level low</li> <li>2. Release valve not closing</li> </ol>	<ol style="list-style-type: none"> <li>1. Check / add oil</li> <li>2. Closing the release valve</li> </ol>
Jack will not hold the load	<ol style="list-style-type: none"> <li>1. Release valve not closing</li> <li>2. Hydraulic oil is contaminated</li> <li>3. Pump leaking</li> </ol>	<ol style="list-style-type: none"> <li>1. Closing the release valve</li> <li>2. 3. Contact authorized service agent</li> </ol>
Lift arm will not lower	1. Pump cylinder binding	1. Contact authorized service agent
	2. Parts worn	
	3. Internal component damage	
	4. Return spring broken or unhooked	
	5. Lift arm linkage either bent or binding	
	6. Still have air in the hydraulic system	
After hydraulic purging, the jack still can reach the maximum by 10 pumps		1. Operate according to manual Part 4.5
Poor lift performance	<ol style="list-style-type: none"> <li>1. Fluid level low</li> <li>2. Hydraulic unit malfunction</li> </ol>	<ol style="list-style-type: none"> <li>1. Ensure proper fluid level</li> <li>2. Discontinue use, contact authorized service agent</li> </ol>

## 8. Exploded View and Parts List

### 8.1 The Whole Machine

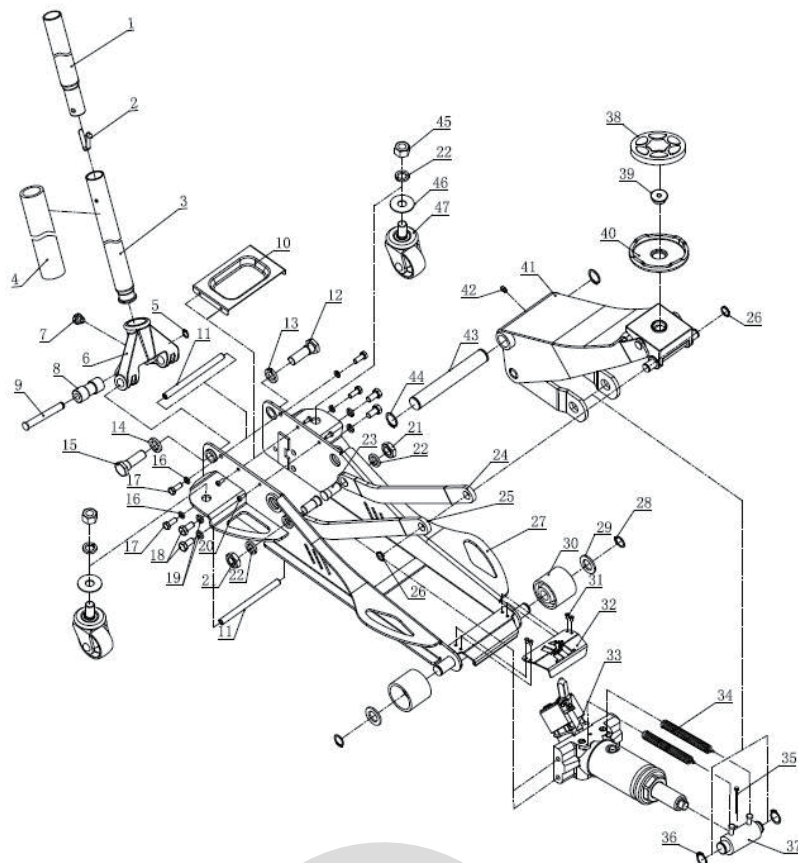

**Part List**

<b>Number</b>	<b>Description</b>	<b>Qty</b>	<b>Number</b>	<b>Description</b>	<b>Qty</b>
1	Upper Handle	1	25	Right adjust plate	1
2	Pin	1	26	Retain ring	2
3	Down Handle	1	27	Frame assy	1
4	Sleeve for Handle	1	28	Retain ring	2
5	Retain ring	1	29	Washer	2
6	Handle seat	1	30	Front wheel	2
7	Limit screw	1	31	Screw	4
8	Roller	1	32	Logo plate	1
9	Roller pin	1	33	Pump assy	1
10	Tools tray	1	34	Spring	2
11	Limit bar	2	35	Pin	1
12	Bolt	1	36	Retain ring	2
13	Lock washer	1	37	Support bar	1
14	Lock washer	1	38	Rubber pad	1
15	Bolt	1	39	Screw	1
16	Lock washer	4	40	Saddle	1
17	Bolt	4	41	Lift frame	1
18	Bolt	4	42	Oiling cup	1
19	Lock washer	4	43	Lift shaft	1
20	Screw	4	44	Retain ring	2
21	Nut	2	45	Nut	2
22	Lock washer	4	46	Washer	2
23	Screw	2	47	Casters	2
24	Left adjust plate	1			





### DISPOSAL

The device may not be disposed of with household rubbish.  
This appliance is labelled in accordance with European Directive 2012/19/UE concerning used electrical and electronic appliances (waste electrical and electronic equipment - WEEE).  
The guideline determines the framework for the return and recycling of used appliances as applicable throughout the EU. To return your used device, please use the return and collection systems available to you.